

~~1. Answer each question to the best of your ability~~

# ECEN3233 Spring 2007

## Exam 1

Thursday, Feb., 8th

10:30am-11:20am

(Total Points 100)

Name: Solutions

Note:

1. This exam is closed book and closed notes. You can bring one single-sided sheet.
2. Totally 10 pages including this cover page.
3. Read each question carefully. If something appears ambiguous, clearly state your assumptions. Clearly indicate each answer by enclosing it in a box. Show all your work.
4. By taking this exam you agree that all work is your own. All work is to be done on the attached sheets – use the backs only if necessary. Clearly identify your work. Write your name at the top of every sheet. Failure to follow instructions may result in a reduction in your score.

1. Show a circuit implementation for a logic function given by:

$$F(X,Y,Z) = X'Z + XY + Y'Z$$

a) Using two-level AND, OR and NOT logic gates to implement the above function. (10 points)

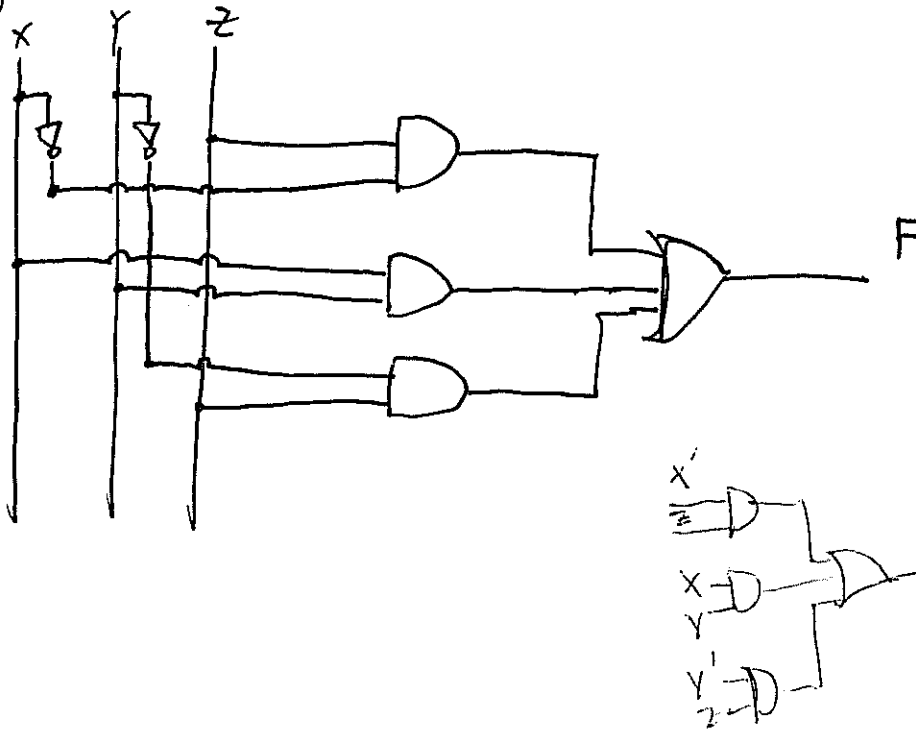

b) Using only NAND and NOT logic gates to implement the same function. (5 points)

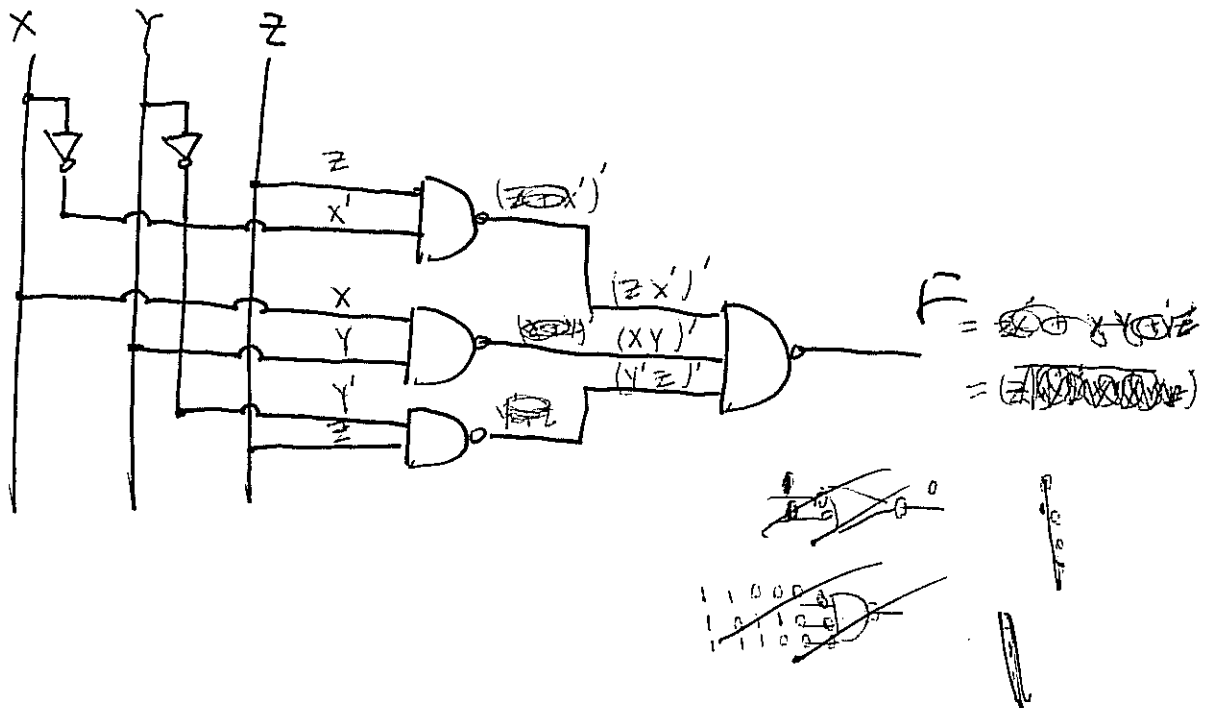

2. Proof and simplification.

a) Prove that the following Boolean expressions are equivalent. (6 points)

$$X'Y' + XY = (XY' + X'Y)'$$

$$\begin{aligned} (XY' + X'Y)' &= (X' + Y) \cdot (X + Y') \\ &= X'X + X'Y' + XY + Y'Y' \\ &= X'Y' + XY \end{aligned}$$

$$X'Z + XY = X'Y'Z + YZ + XY$$

$$\begin{aligned} X'Y'Z + YZ + XY &\neq X'Y'Z + YZ + XY \quad \neq (X'Y' + Y)Z + XY \\ &= \underline{X'Y'Z} + YZ + XY + \underline{X'Z} \quad (\text{Consensus law}) \\ &= X'Z + YZ + XY \quad (\text{Consensus law}) \\ &= X'Z + XY \end{aligned}$$

b) Simplify the following logic equation algebraically: (4 points)

$$F(X, Y, Z) = Y'Z' + X'Y' + X'Z + YZ'$$

$$\begin{aligned} &= Z' + X'Y' + X'Z \\ &= Z' + X'Y' + X'Z + X' \quad (\text{Consensus law}) \\ &= Z' + X' \end{aligned}$$

3. Given the following Boolean function:

$$F(A,B,C,D) = \sum m(0, 1, 2, 8, 10) + d(3, 5, 6, 7, 11, 15)$$

a) Identify each of the following product terms in one of the following: an essential prime implicant, a non-essential prime implicant, not a prime implicant, or not an implicant. (4 points)

1.  $A'B'$

Non-essential Prime Implicant.

2.  $AB'D'$

Not a prime implicant

3.  $A'C'$

Not an implicant

4.  $A'C$

Non-essential Prime implicant

b) Realize  $F(A,B,C,D)$  in a minimized two-level product of sums form. (6 points)

$$F(A,B,C,D) = \textcircled{B'+D'} \cdot \textcircled{A'+D}$$

~~$$AB'+B'D'+A'D$$~~

~~$$AB'+B'D$$~~

$$B'(A'+D)$$

4. Consider the Karnaugh map of Boolean function  $F(A,B,C,D)$  below.

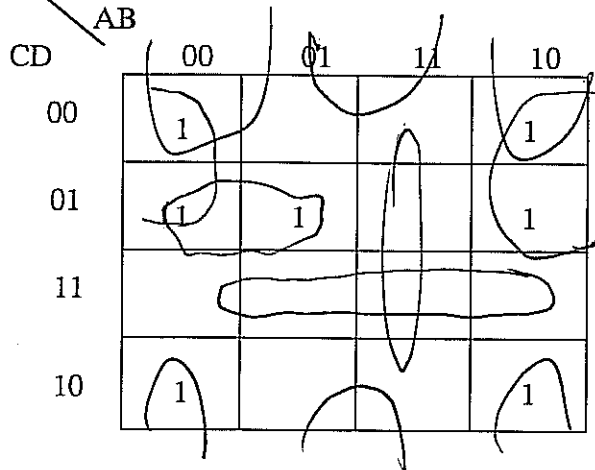

a) Write  $F(A,B,C,D)$  in minimized SOP notation (5 points) +2

$$F = B'D' + B'C' + A'c'D'$$

b) Write  $F'(A,B,C,D)$  in minimized SOP notation (5 points) +2

$$F' = CD + AB + BD'$$

c) Write  $F(A,B,C,D)$  in minimized POS notation. (5 points) +2

$$F = (C + D') (A' + B') (B' + D)$$

d) Write  $F'(A,B,C,D)$  in minimized POS notation. (5 points) +2

$$F' = (B + D) (B + C) (A + C + D')$$

Derive

5. For the Boolean function  $F(A, B, C, D) = A'C + AB' + B'CD$

a) Write the canonical sum of products expression for F using decimal shorthand. (5 points)

$$\begin{aligned}
 F &= \cancel{A'CB+B'} + \cancel{AB'(C+C')} + \cancel{B'CD} \\
 &= A'(B+B')C(CD+D') + AB'(C+C')(D+D') + AB'CD + A'B'CD \\
 &= \sum m(2, 3, 6, 7, 8, 9, 10, 11)
 \end{aligned}$$

b) Write the canonical product of sums expression for F using decimal shorthand. (5 points)

$$F = \prod M(0, 1, 4, 5, 12, 13, 14, 15)$$

6. Consider the function  $F = XY + WZ$ .

a) If it is implemented as written with CMOS AND, OR and NOT gates, how many transistors are needed? (5 points)

18

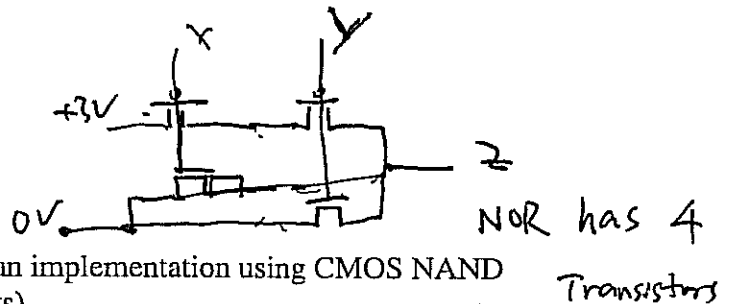

b) If implementation from part a) is converted to an implementation using CMOS NAND gates, how many transistors are needed? (5 points)

12

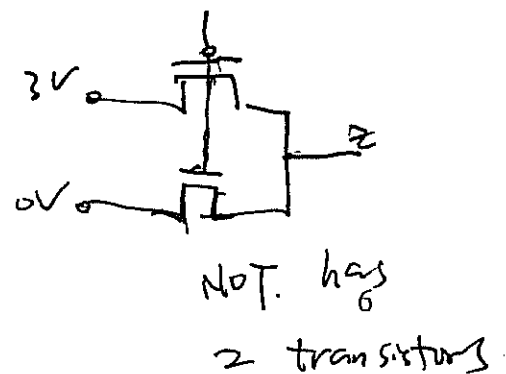

7. A new gate is shown schematically below.

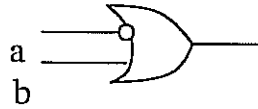

a) Write the equation of the output as a function of input a and b. (5 points)

$$F = a' + b$$

b) Show that it is possible to create all possible logic functions with this gate. In other word, prove that this gate is functionally complete. (5 points)

It can implement a NOT <sup>gate</sup> ~~gate~~ <sup>OR gate</sup> and AND gate

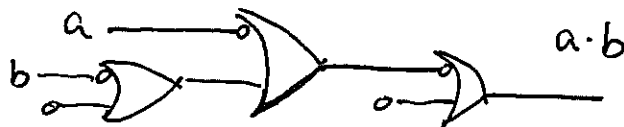
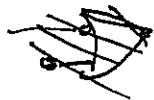
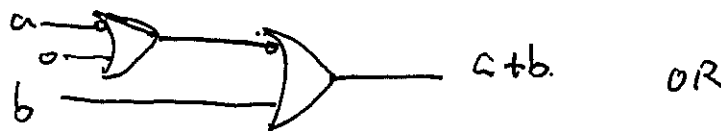
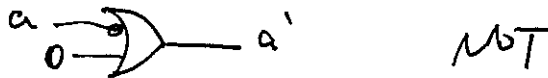

$$(a' + b')' = a \cdot b$$

8. Multiplexers

a) Implement the following logic function using a 4-1 multiplexer (7 points)

$$f(a,b,c) = a'b'c + b$$

$$\begin{aligned} f &= a'b'c + (a+a')b(c+c') \\ &= a'b'c + abc + abc' + a'b'c + a'b'c' \\ &= a'b'c + ab \cdot 1 + a \cdot b \cdot 1 + ab' \cdot 0 \end{aligned}$$

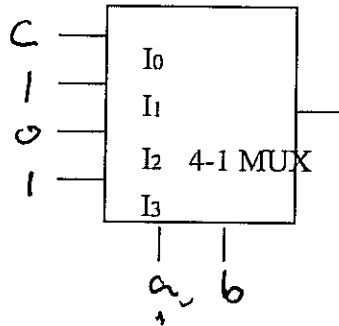

b) Implement the following function on a single 2-1 multiplexer using as few external gates (choose from AND, OR, NOT) as possible. (8 points)

↓

a	b	c	f
0	0	0	1
0	0	1	0
0	1	0	1
0	1	1	1
1	0	0	1
1	0	1	0
1	1	0	0
1	1	1	0

2 gates.

~~a'b'c~~

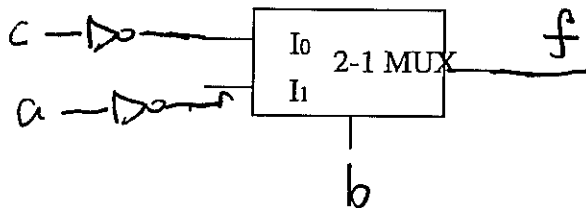

$$f = c'b' + a'b$$

Enumerate all 3 possibilities